

ITEM NO.	PART NUMBER	DESCRIPTION	QTY.
1	90-411	OUTDOOR EPOXY	1
2	CU-436	COPPER CONDUCTOR	1

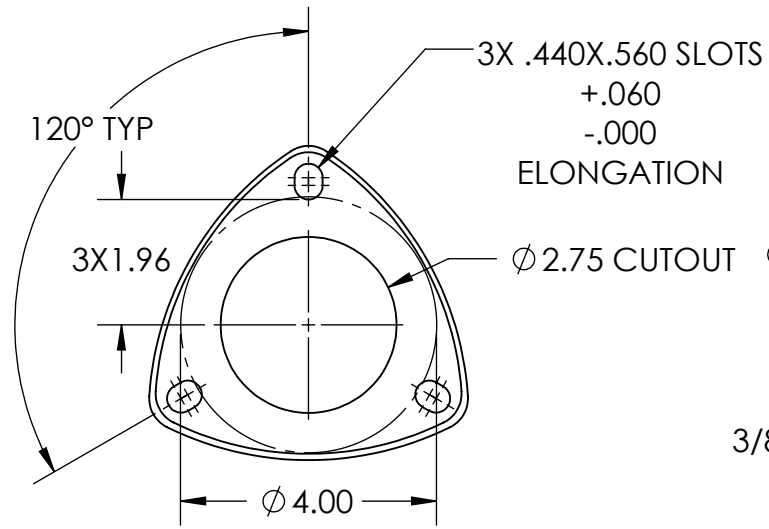

MOUNTING PLATE (MP-132)

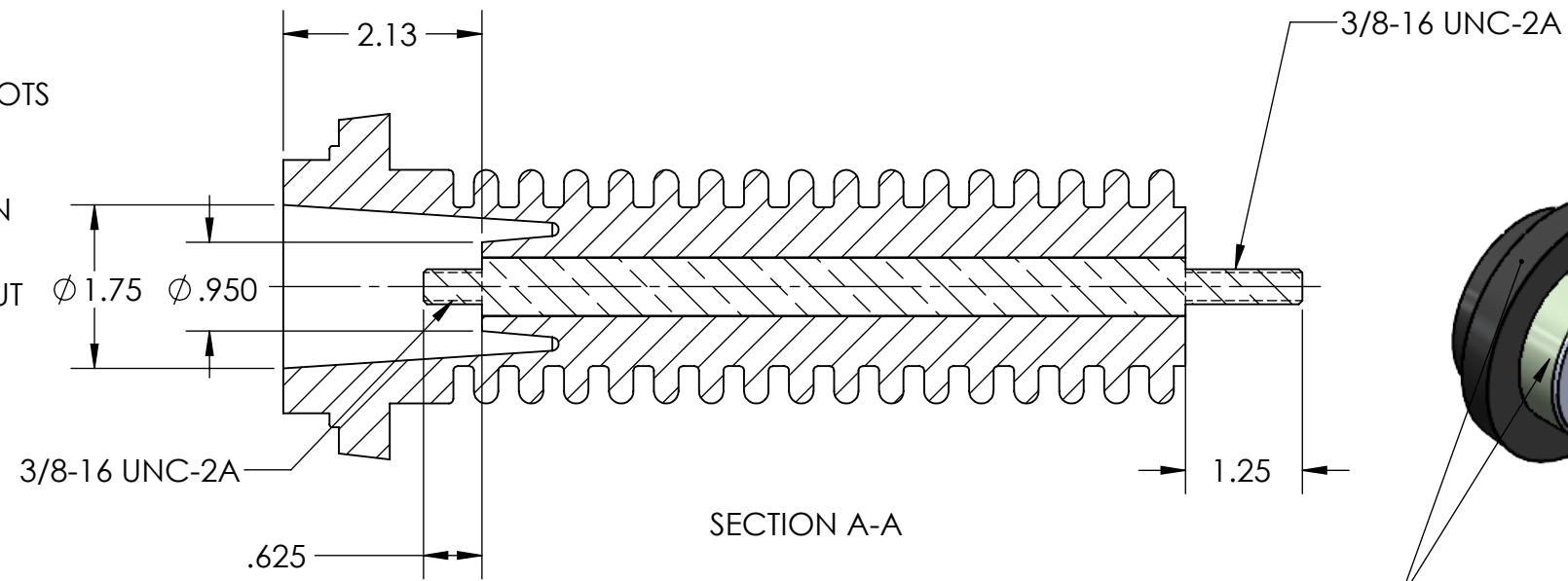
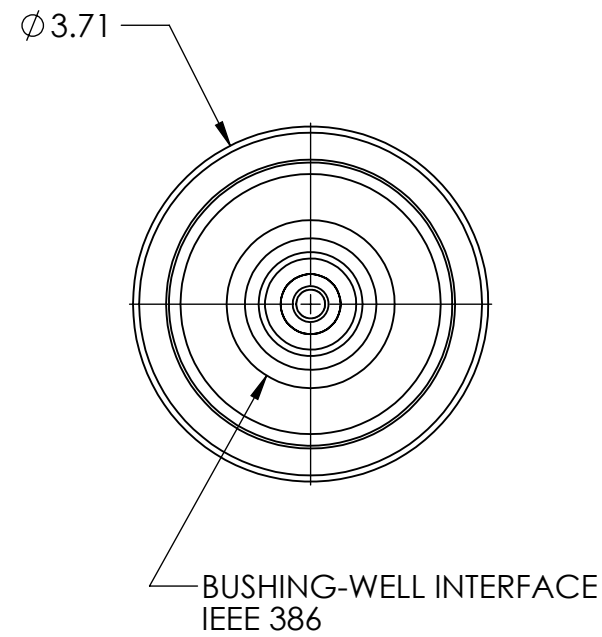

SECTION A-A

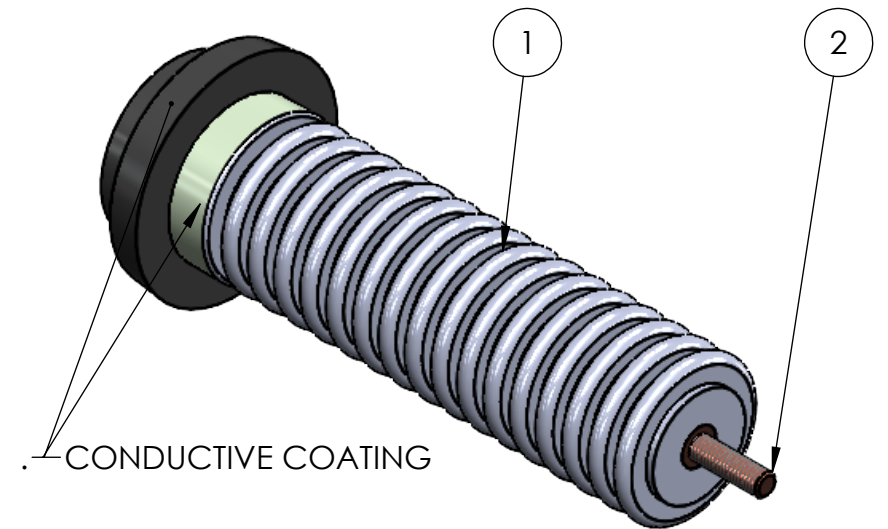

ISO VIEW

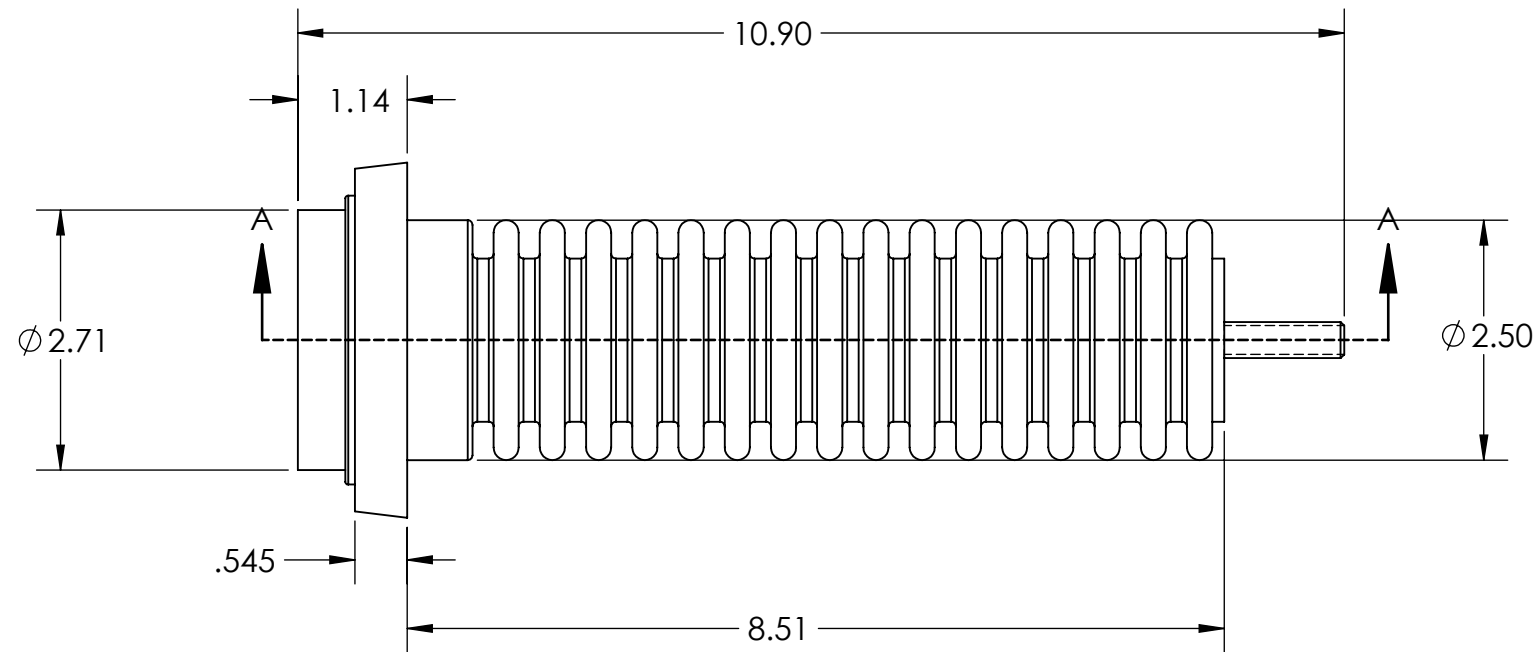

**SPECIFICATIONS**

CURRENT RATE	200 A
VOLTAGE CLASS	25 kV
B.I.L.	125 kV
TANK OPENING	2.88" MIN
LEAKAGE DISTANCE	16.00"
GASKET	AC86-223
MOUNTING PLATE	MP-132

CURRENT CAPACITY (RMS)		MOMENTARY WITHSTAND	
CONTINUOUS (AMPS)	8 HRS OVERLOAD (AMPS)	10 CYCLES (AMPS)	3 SECONDS (AMPS)
200 A	300 A	10000 A	3500 A

UNLESS OTHERWISE SPECIFIED:  
 DIMENSIONS ARE IN INCHES  
 TOLERANCES:  
 ANGULAR:  $\pm 0.5^\circ$   
 TWO PLACE DECIMAL  $\pm 0.05$   
 THREE PLACE DECIMAL  $\pm 0.005$   
 THIRD ANGLE PROJECTION



PROPRIETARY TECHNICAL INFORMATION TO BE MAINTAINED IN CONFIDENCE AND NOT DISCLOSED TO ANY THIRD PARTY.

**CROSSLINK TECHNOLOGY INC.** 

TITLE: **BUSHING WELL**

SIZE **B** DWG. NO. **90-411** REV **2**

SCALE: 1:2 SHEET 1 OF 1